

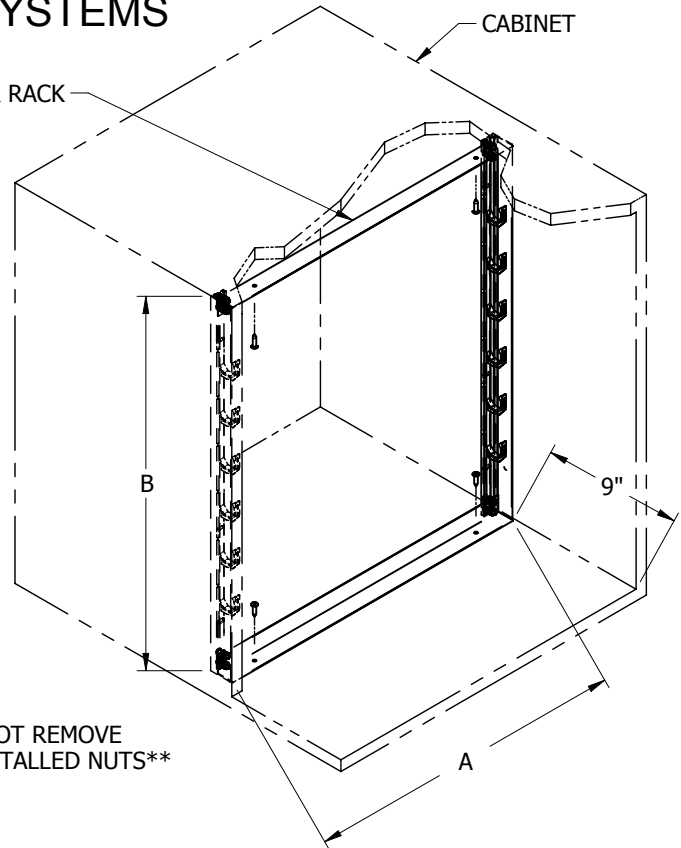

ASSEMBLY INSTRUCTIONS IN-COUNTER RACK MODEL INC 21", 24", 30" SYSTEMS

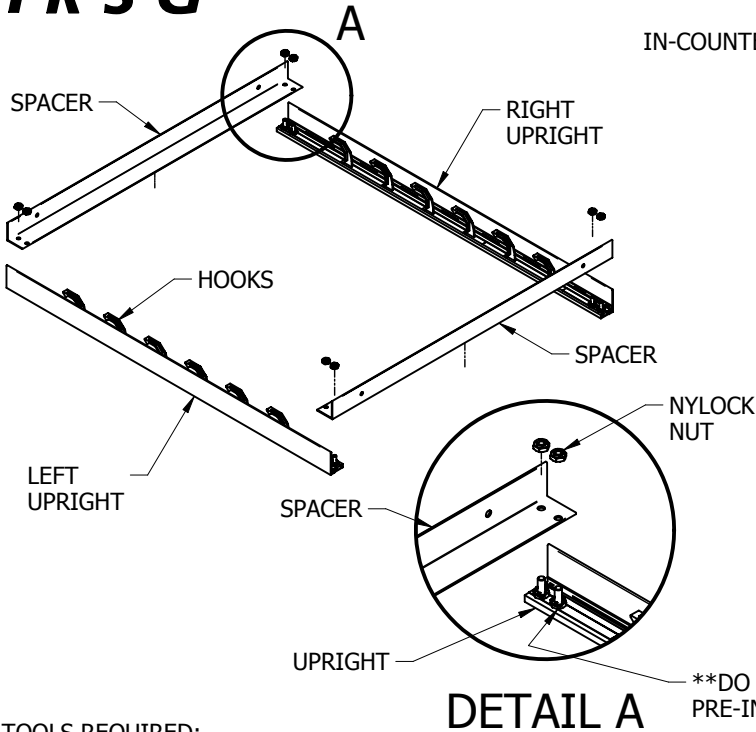

TOOLS REQUIRED:

- NUT DRIVER OR SOCKET SET (FOR RACK ASSEMBLY)
- TAPE MEASURE
- SCREW DRIVER
- DRILL AND 1/8" BIT

RACK ASSEMBLY:

1. LAY ALL OF THE PIECES ON A FLAT WORK SURFACE, AS SHOWN, SO THAT THE HOOKS ARE ON THE INSIDE OF THE RACK.
2. POSITION THE TOP AND BOTTOM SPACERS BY SLIDING THE HOLES AT THE ENDS OVER THE SCREWS ALREADY INSTALLED IN THE UPRIGHTS.
3. SECURE THE SPACERS USING THE NYLOCK NUTS INCLUDED WITH THE RACK. (SEE DETAIL A)
4. TIGHTEN ALL HARDWARE.

INSTALLATION OF IN-COUNTER RACK:

1. PLACE THE IN-COUNTER RACK INTO THE CABINET WITH THE HOOKS FACING THE FRONT AND SLIDE IT BACK UNTIL THE FRONT OF THE FRAME IS 9" FROM THE CABINET OPENING.
2. MARK THE LOCATION OF THE MOUNTING HOLES IN THE TOP AND BOTTOM SPACERS AND REMOVE THE UNIT FROM THE CABINET.
3. DRILL 1/8" STARTER HOLES IN THE LOCATIONS MARKED IN THE PREVIOUS STEP. BE CAREFUL NOT TO DRILL THROUGH THE TOP SURFACE OF THE CABINET.
4. POSITION THE IN-COUNTER RACK IN THE CABINET AND ALIGN THE HOLES IN THE TOP AND BOTTOM SPACERS WITH THE DRILLED HOLES IN THE CABINET.
5. SECURE USING THE APPROPRIATE FASTENERS.

SUGGESTIONS FOR INSTALLATION:

1. I.R.S.G. CUSTOM SERIES IN-COUNTER RACKS CAN BE ORDERED IN CUSTOM SIZES TO FIT ANY HEIGHT OF CABINET.
2. THE CUSTOM SERIES RACK CAN BE MODIFIED BY THE USER BY CUTTING ONE END OF EACH UPRIGHT TO THE DESIRED LENGTH, TRIMMING THE HOOKS, AND RE-DRILLING THE BOLT HOLES IN THE UPRIGHTS.
3. IN-COUNTER RACKS MUST BE PROPERLY INSTALLED. FOR THE BEST RESULTS, INSTALL THE RACK IN THE CABINET WITH NO MORE THAN 1/4" CLEARANCE ABOVE THE TOP OF THE IN-COUNTER RACK.
4. IN-COUNTER RACKS ARE INTENDED TO HOLD I.R.S.G. HANGERBARS. DO NOT USE THEM FOR ANY OTHER PURPOSE.

IN-COUNTER RACK DIMENSIONS			
HANGERBAR MODEL	A	B	
	OVERALL WIDTH	24" RACK HEIGHT	30" RACK HEIGHT
21	20-15/16"	23-3/4"	29-7/8"
24	24-1/2"	23-3/4"	29-7/8"
30	29-15/16"	23-3/4"	29-7/8"

International Retail Services Group

Customer Service: (888) 598-2001 · Web Site: www.irsg.com